

INVERTED RESEARCH MICROSCOPE

NIB1000



NINGBO YONGXIN OPTICS CO., LTD.

Add: No.169 Mujin Road, Hi-tech Industry Park, Ningbo, China
P.C.: 315048 Tel: 0574-87915350 / 87903144 / 87915342
<http://www.yxopt.com>



NANJING JIANGNAN NOVEL OPTICS CO., LTD.

Add: No.9 Hengda Road, Economic-Technological Development Area, Nanjing, China
P.C.: 210038 Tel: 025-87720110 Fax: 025-85800086
<http://www.jnoec.com>



Nexcope®

Stable and highly scalable live cell imaging platform

NIB1000 provides an advanced imaging platform with 25mm field of view, to meet experimental needs of large flux observation. With high speed full frame CMOS camera, which has greatly improved shooting efficiency. Full-motorized NIB1000-AT and coded NIB1000-M realize integration of multimodal imaging technology such as bright field, fluorescence, DIC, phase contrast and so on, both models can choose single or double layer optical path, anti-focus shift module can be optional which is more suitable for long-time dynamic imaging of living cells. NIB1000 provides stable and reliable platform for confocal, superresolution, single molecule and other advanced microscopic imaging technology.

In addition, the touch screen could achieve smooth control of electric components while recording status of each sensor, recording user usage habits, switch application scene by one-click. Combined with powerful acquisition and analysis software, NIB1000 is full of stability and scalability, meet a variety of experimental needs, provide reliable, repeatable data.

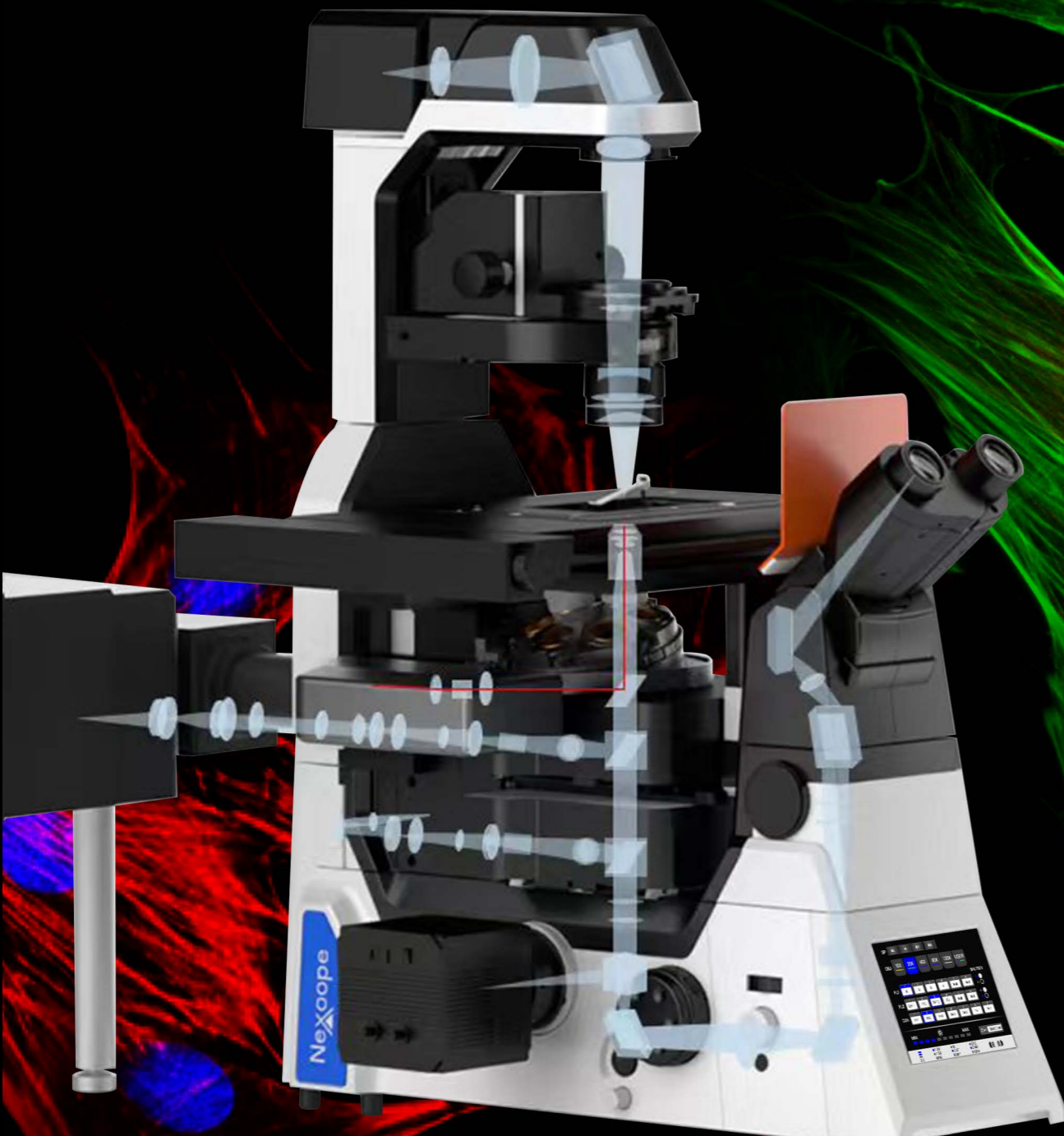

Double layer optical path



Single layer optical path



NIB1000-AT motorized Scientific research grade inverted microscope

It could realize high-speed, full-automatic component linkage, compatible with adaptive focusing systems (AFS), especially suitable for high-level living cell research. double layer optical path provides more scalability possibilities, providing perfect flexible and open inverted microscopic imaging platform for advanced microtechnic such as living cell, confocal, super resolution.

Double layer optical path



Single layer optical path



NIB1000-M Coded scientific research grade inverted microscope

Scientific research grade inverted microscope for advanced life science research, integrating bright field, phase contrast, Hoffman, DIC, fluorescence etc. observation methods. Intelligent coding components record interactive information and workflow, Z-axis motorized focusing can simplify focusing steps, reduce visual fatigue and improve work efficiency in daily research, teaching and pathological diagnosis.

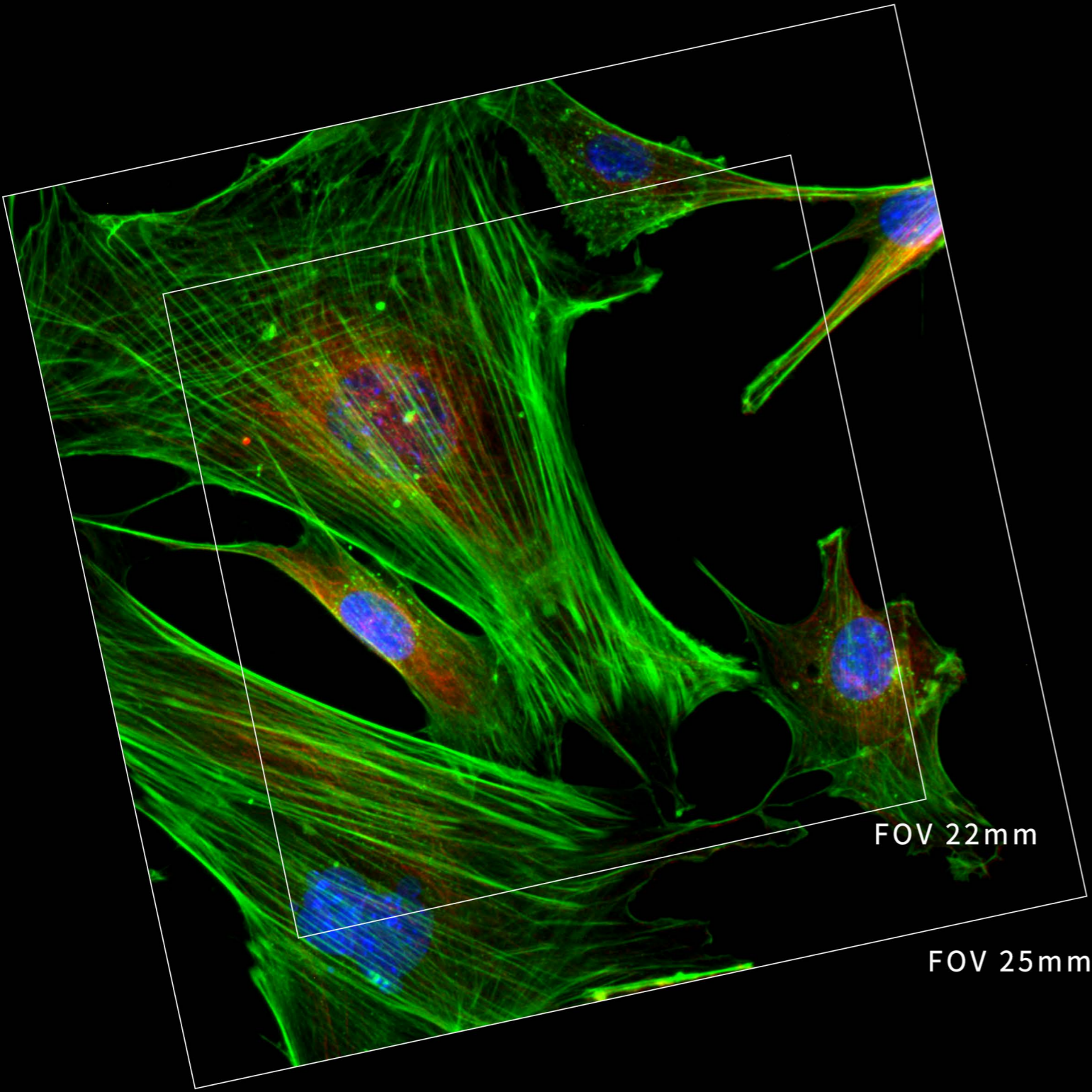

Incomparable 25mm field of view

With the research trend towards large-scale, high-flux and intelligent solutions, demand for faster data acquisition and higher throughput is increasing day by day. No matter it is bright field imaging or fluorescence imaging, NIB1000 large-area illuminator and large-field fluorescence attachment provides uniform and bright cell imaging. Large size sensors and imaging interfaces that truly maximize performance of large format detector and provide perfect imaging platform for the future as camera technology continues to evolve rapidly.

Large field illumination module

Bright and large area transmission illumination

Transmission illumination module adopts high power LED illumination to guarantee full field of view brightness and uniform illumination, ensure get clear, consistent results from high magnification DIC applications, provide stable light source for seamless image stitching.



Large aperture reflective fluorescent illuminator

A compact optical fiber illumination device for FOV25mm fluorescence imaging is designed, equipped with high power LED light box, provides wide spectrum high transmittance lighting including ultraviolet light, meanwhile compatible with large aperture fluorescent filters, provide fluorescence images of FOV25mm with high signal-to-noise ratio.



Large aperture observation optical system

Equipped with large diameter tube lens to expand light flow, cooperate with large target surface CMOS sensor, both bright field and fluorescence imaging could FOV25mm field of view.



FOV25 imaging objective

The objective with superior image flatness guarantees high quality images. Maximize potential of FOV25 objectives significantly speeds up data collection.



Camera for large volume data acquisition

NEXCAM-MAX2400 High sensitivity monochrome camera, full frame sensitive Chip, target surface 36.0x23.9mm, 24 million pixel CMOS Image sensor, maximum acquisition speed could reach 114fps, realize digital imaging of the largest field of vision.





Living cell culture system

Living cell culture system is designed for imaging observation of live cells. Precisely control temperature of microscope platform while maintaining the internal temperature, humidity and CO2 concentration of culture dish, providing stable cultivation environment. for long-term live cell experiments.



AFS realize stable and reliable imaging results

Focusing stability is key factor of live cell imaging, even in constant temperature and humidity environment, focus position of microscope also varies slightly because of temperature and vibration changes, which greatly affects long-term observation of living cells.

NIB1000 adopt independent focusing design, maximumly reduce impact on Z axis from other mechanical components. Brand new designed APS (Adaptive Focus System), adaptive anti-focus shift system, eliminate focus shift. Even when using high-magnification, high-numerical aperture objectives and advanced imaging technologies, such as super-resolution, confocal, TIRF, can still be clearly focused.

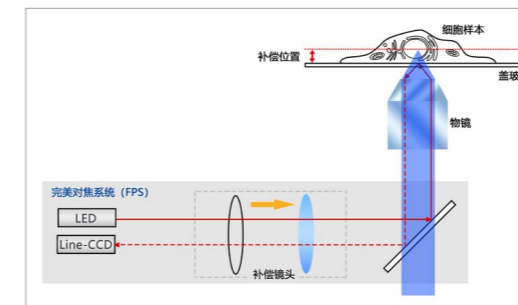

APS (Adaptive Focus System)

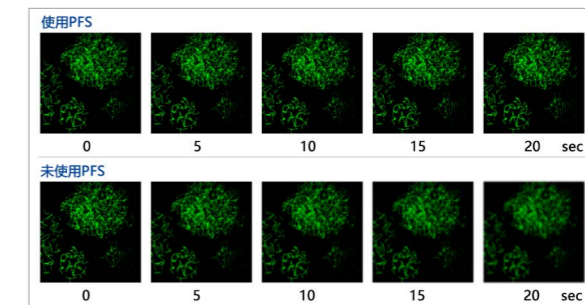

Correction of focal drift during long-term imaging

Ideal living cells microscopic experiments platform

Even small changes of temperature and vibration in imaging environment can greatly affect stability of focus, adaptive anti-focus shift system (AFS) eliminates focus drift through static and dynamic measurements, high-brightness LED fluorescent light source and live cell culture system enables NIB1000 realize multi-day living cell time-lapse observation, making it an ideal imaging tool for more demanding focused experiments.

High specification LED fluorescent illumination system

LED 4 enables up to 4 channels LED illumination, highly matching fluorescent dye commonly used in market, excitation energy concentrated, high brightness, meet the daily experimental fluorescence imaging need. long life, do not need to change bulb. Compared to traditional mercury 空格 lamps, it reduce photobleaching and phototoxicity, which are very friendly to live cell samples. It is an ideal microscope light source which is sustainable, energy saving and low carbon, environmental protection.

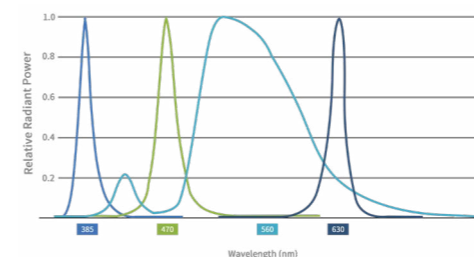



Intuitive and ergonomic control operation

NIB1000 integrates a large number of advanced human-computer interaction technologies, which enables fine control of imaging. Intuitive and easy microscope operation interface can make the complex operation procedures become very simple, so that researchers can work more efficiently and comfortably, which helps to reduce researchers' fatigue while the system minimizes damage to living cells.

Interactive operation

NIB1000 was creatively designed front panel as a touch screen, which makes human-computer interaction more convenient, powerful and expandable. Left and right sides reserved knobs and buttons, even in a dark lab, it is easy to control, which allows researchers to focus more on the experiment itself, rather than complex microscope operation.



Front 5.6 inch touch screen

Touch screen control movement of electric parts such as objective, double layer/single layer fluorescent turnable, condenser, light intensity, motorized platform speed, motorized Z-axis speed, main body splitting port, ESC escape, FN key, objective focus. Display real-time, display objective magnification, transmitted illumination brightness, fluorescence band, output port, XYZ position and speed and other component status.



High speed electric control

Operation and conversion speed of objectives, filters, the XY stage and the observation module are greatly improved, enabling an easy operating environment for researchers to concentrate on routine observations and images. The joystick that can control the stage freely allows the microscope working as your eyes and hands, making it easy to use.



Joystick with built-in touch panel

The joystick comes with touch screen, which can set the state of main body, motorized platform control by multi-level and also motorized focus, built-in function key and AFS focus stabilization control.



Unparalleled optical system

NIB1000 high quality infinity optical system, equipped with bright field, fluorescence, phase contrast, DIC, hoffmann and other complex observation methods, no matter which observation method, you can get bright high signal-to-noise ratio of the original image, with its excellent optical performance and reliable reliability are highly valued by researchers

Phase contrast

The condenser has built-in phase contrast ring, which can be converted from bright field observation to phase contrast observation by turning the condenser turntable. Semi-apochromatic phase contrast objective provides clear imaging with high contrast.



Fluorescence

Using the newly designed filter group, cutoff depth of single-channel fluorescence filter reaches OD6, and the image with high signal-to-noise ratio can be obtained, which can be used for single-molecule and single-cell experiments. illumination module spectrum design covers a wide wavelength range, and six-hole filter module turntable meets needs of multi-color fluorescence. High power LED fiber optic light source is bright and safe.



DIC(Differential interference)

High quality large field of view differential interference optics system covers all magnifications, providing uniformly clear and detailed images with high resolution and contrast for each sample.



Hoffmann contrast

High contrast ratio phase contrast imaging technique for unstained, transparent samples such as egg cells. Hoffmann phase contrast components provide pseudo-three-dimensional image with the appearance of shadow casting. The contrast direction of each sample can be easily adjusted.

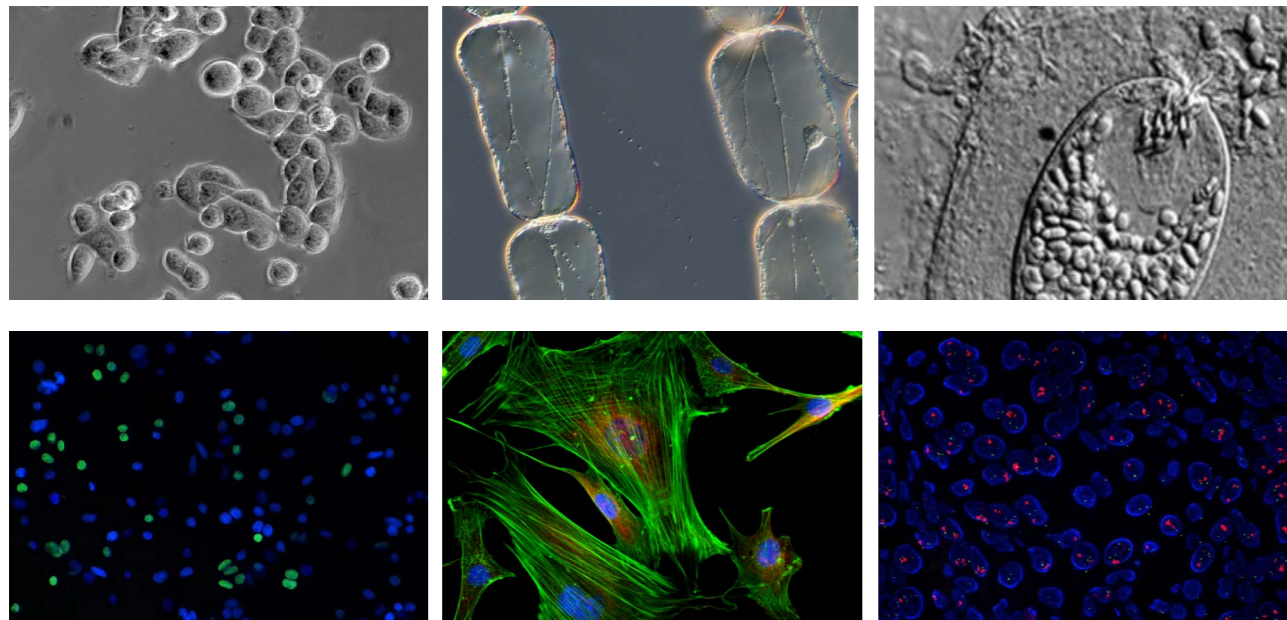

Nomis Pro X microscope control and analysis

Nomis Pro X, software platform of NIB1000, integrates hardware control, image acquisition and processing into one software. Nomis Pro X makes it easier for you to use this microscope, even for various complex microscope operations. It can also be quickly realized through the linkage of hardware and software. Image processing includes image measurement, image adjustment, filtering, noise reduction, deconvolution, SIM reconstruction, etc., which can meet the needs of different work applications.

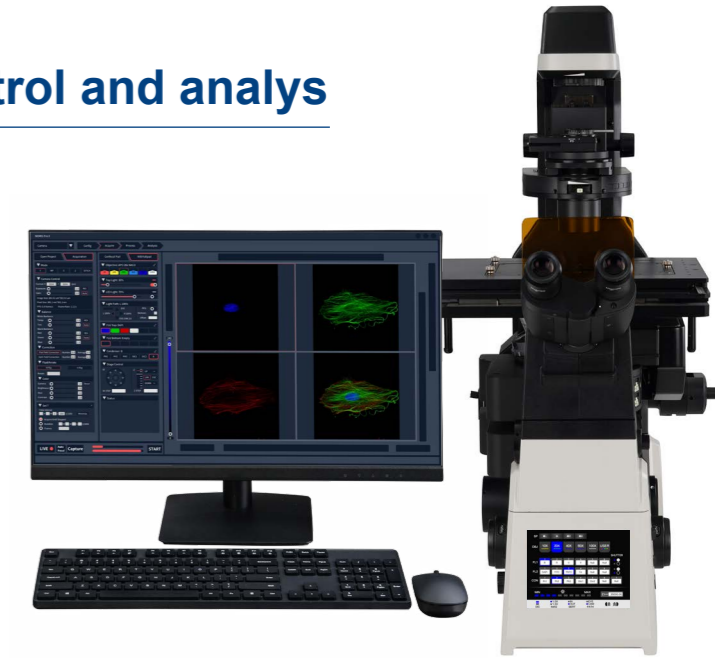

Multi-dimensional imaging

Able to remember customized viewing modes for multiple imaging needs such as multi-channel, multi-position, time-lapse imaging or large image stitching.

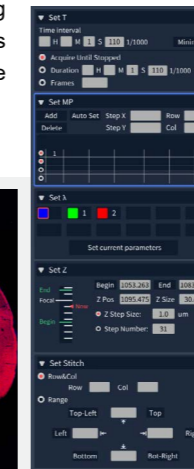
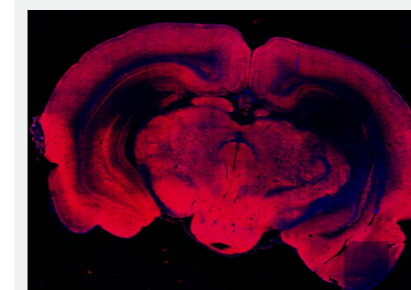

Multi-dimensional image display

Multi-channel situation, delay, Z-axis stacking, XY axis position and image stitching information of the image can be visually displayed in one window to improve the repeatability of experimental results.

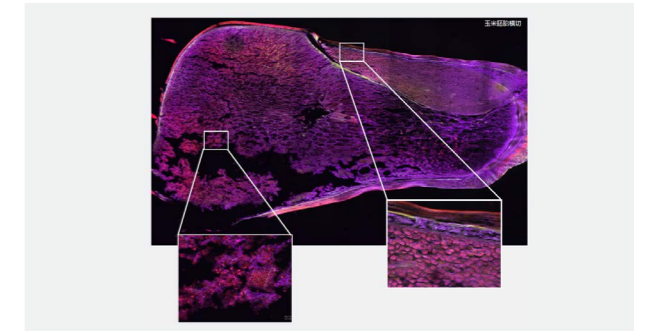

High speed hardware control

Various electric components of the microscope controlled by software, such as objective conversion, focusing, condenser conversion, fluorescence module conversion, etc.



Deconvolution

The two dimensional image can be deblurred. It can be deconvolved multiple times, and results can be viewed and adjusted on screen. 3D deconvolution can also be used for multi-dimensional images.

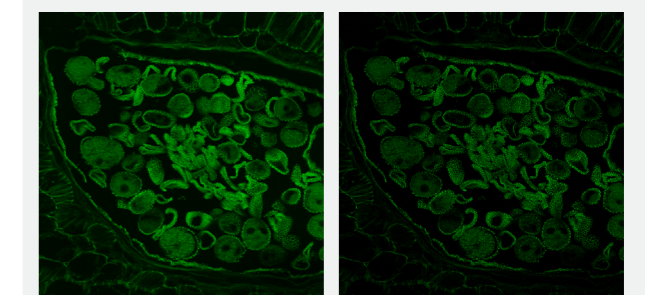

反卷积前

反卷积后

Excellent system scalability

Adaptive Anti-Focus Shift System (AFS)

Automatically correct focus drift caused by temperature changes and mechanical vibrations.



Stage lifting position device

Stage can be raised to allow installation of a second fluorescent illuminator and filter module turntable.



Fluorescent filter module turntable

Both manual coding model and electric intelligent model are available, compatible with FOV25 wide field of view.



Electric platform

High-speed electric platform with grating ruler for accurate positioning and high repeatability.



Manual platform

Long working stroke, can be a complete observation of the entire hole plate, a variety of platform holders are available.



Live cell culture system

Provide best conditions for the survival of living cells include precise temperature, humidity and gases.



Fluorescent LED light source

With high matching with fluorescent dyes commonly used in the market, which is ready to use, long life and more environmentally friendly.



Condenser turntable

Both manual model and electric model are available, it can automatically switch between seven positions to adapt to different imaging modes.



Laser confocal microscope/super resolution microscope

It can be used as imaging platform of NCF1000 laser confocal microscope to obtain low noise, high contrast and high quality confocal images. Equipped with SIM superresolution system, NSR1000 enables live cell imaging with twice the resolution of traditional optical microscopes.

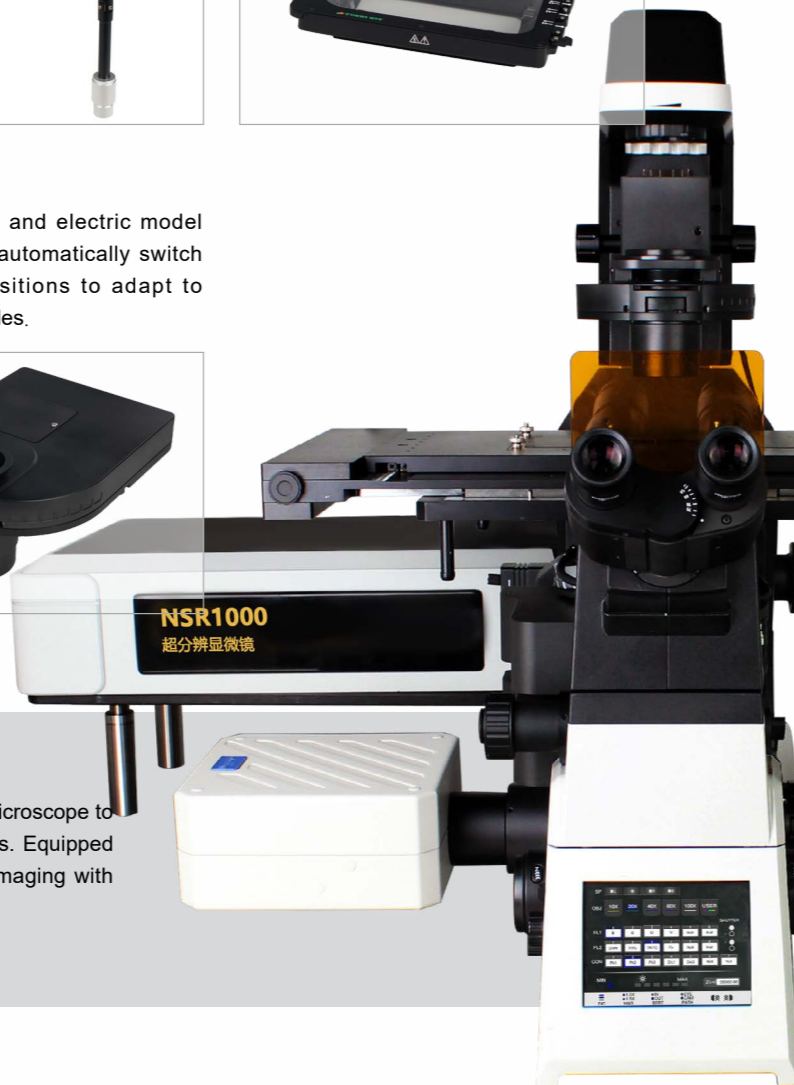

NIB1000 系列显微镜配置图

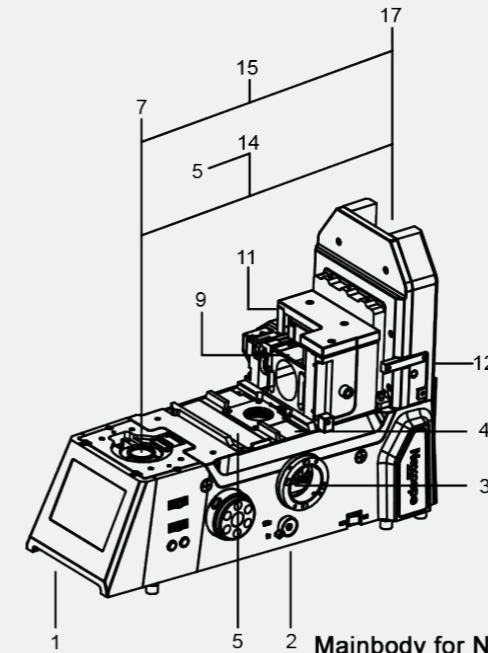

Mainbody for NIB1000-AT

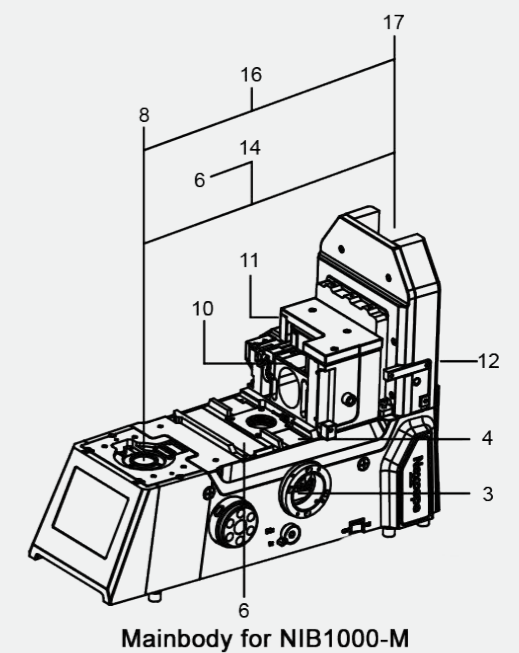

Mainbody for NIB1000-M

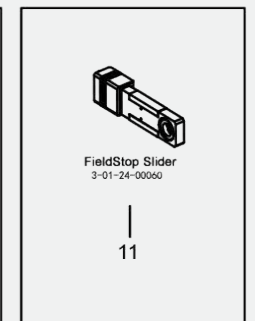
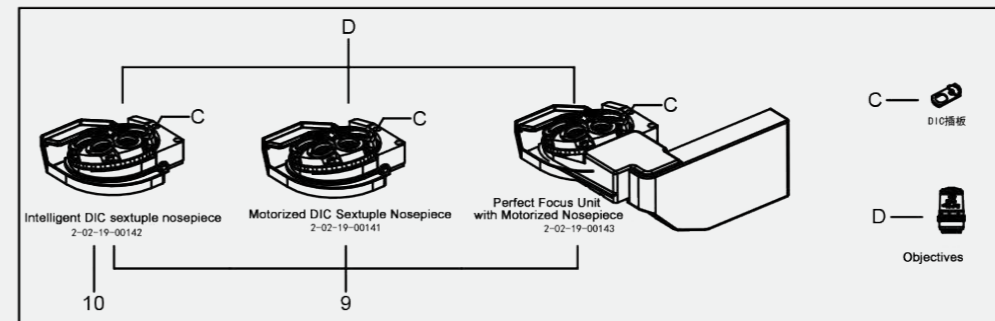
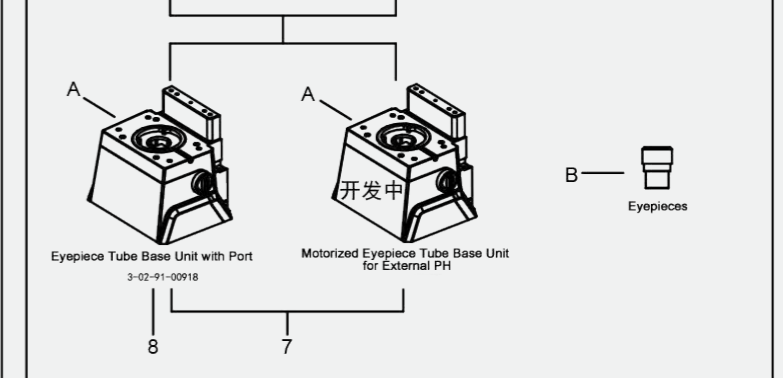
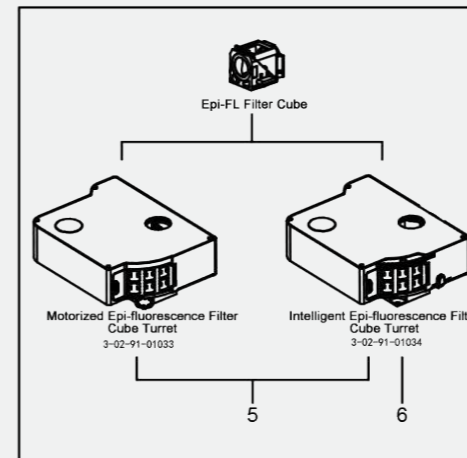
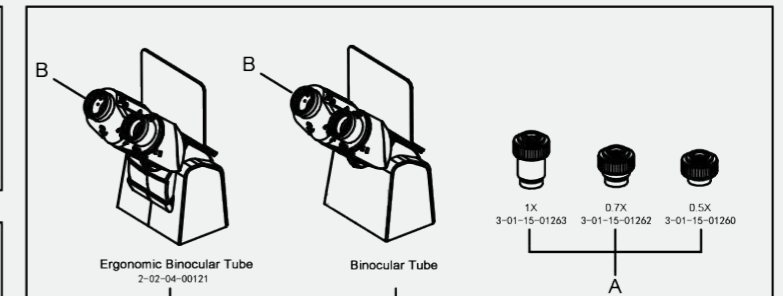
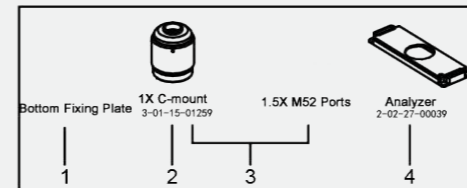

NIB1000 系列显微镜配置图

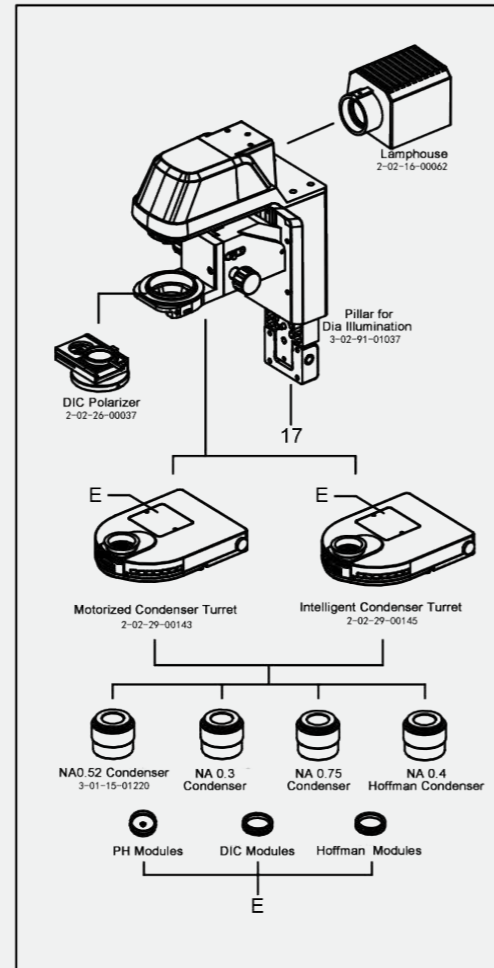
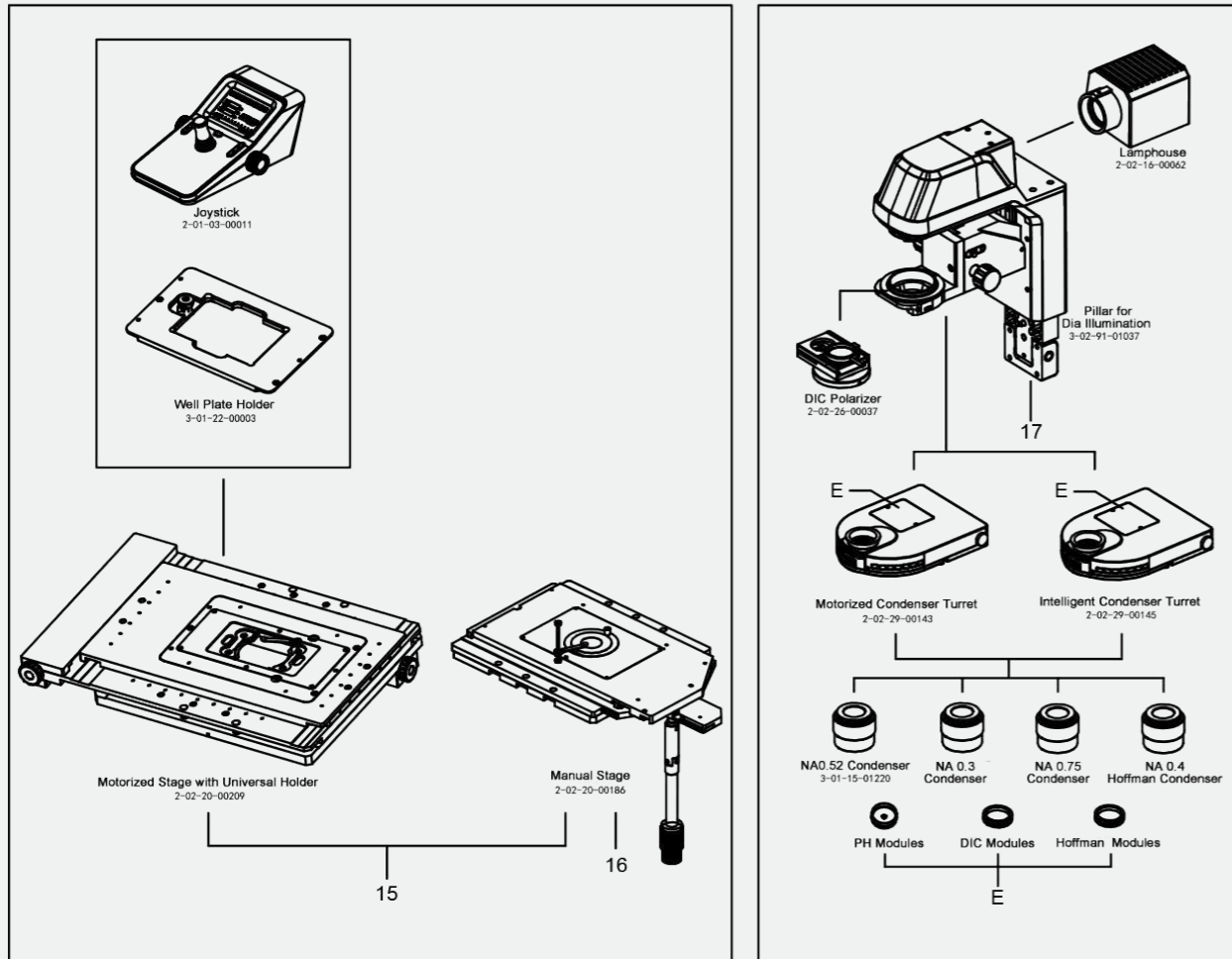
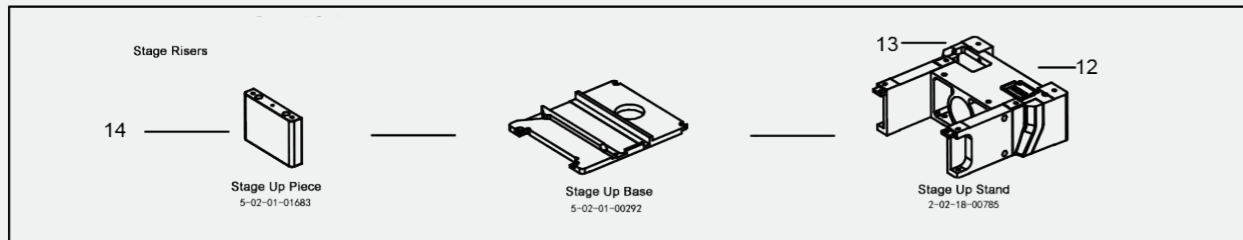
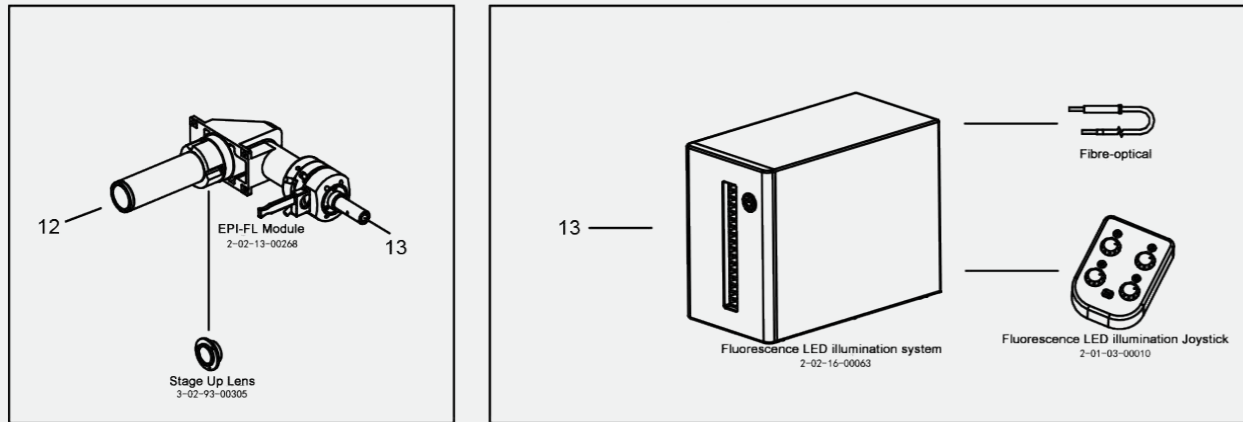

NIB1000 series inverted microscope specification

Item	Specification
Optical system	NIS60 infinite optical system
Eyepiece	10×(22), with diopter adjustment -5 ~ +5 10×(25), with diopter adjustment -5 ~ +5
viewing tube	Seidentopf binocular observation tube, 10-40 degree tilt, pupil distance 47-78mm, eyepiece interface Φ30
viewing tube base	eyepiece/camera(100/0,0/100);eyepiece/camera(100/0,0/100), external phase contrast
Relay lens	0.5X, 0.7X, 1X
Objective	S-APO phase contrast objective, APO objective
Nosepiece	Motorized six-hole nosepiece(expansion slot), M25*0.75 Motorized six-hole nosepiece(expansion slot), M25*0.75;AFS module included
Motorized stage	Electric control (grating type) : travel range 130 mm x 100 mm (table 445 mm x 300 mm) Maximum speed: 25mm/s; Min. :0.1μm - Repetition accuracy: 0.5μm, can be equipped with multi-well plate, 35mm petri dish and slice three special sample clamp adapter; Well Clamper is optional;
Manual stage	Three-layer mechanical moving stage, stage size :340X230mm, moving range 130×85mm
Focusing system	Electric control drive, coarse fine tuning 3-gear switch ((2um/80um800um), stroke: 8.5mm above the focus and 1.5mm below; Minimum step 0.01um Electric control drive, coarse fine tuning 3-gear switch ((2um/80um800um), stroke: 8.5mm above the focus and 1.5mm below; Minimum step 0.01um, repeat accuracy 0.1um(grating type)
Touch LCD	in front of main body, display control light source intensity, objective magnification, fluorescence band, intermediate magnification,turnable position, bertrand lens etc.;
Intermediate magnification switching	Manual 1 x, 1.5 x switching
Bertrand lens	Manual switch in and out of light path, focus adjustable
Port	Electric switching spittingl ratio: left side: visual =100:0; Right side: Visual =100:0; Bottom: Visual =100:0;
Illumination system	Transmitted kohler illumination, 3W LED illumination; Field of view/aperture diaphragm; bend arm can tilt 25°; Electric optical brake optional. EPI illumination: LED optical fiber(wavelength:485nm,525nm,365nm,405nm); Field of view/aperture diaphragm; 2 hole filter insert plate; Lamp source controller; Electric brake (software control) optional
Condenser	7-hole electric turntable for phase contrast, Hoffmann phase contrast, DIC, ND filter, condenser NA=0.52, WD=30mm 7-hole manual turntable, condition detection, for phase contrast, Hoffmann phase contrast, DIC, ND filter, condenser NA=0.52, WD=30mm
Fluorescent turntable	6-hole electric fluorescent turntable (B, G, U, R standard); φ25/30 light pass; Electric optical brake; 6-hole manual fluorescent turntable (B, G, U, R standard); φ25/30 light pass; Manual optical brake;
Double-layer fluorescence heighter	Z-axis heightening base; Fluorescent turntable heightening seat; stage heightening seat
DIC attachment	DIC prism insert can be placed in nosepiece slot; DIC polarizer; analyzer slide plate;
Controller	XYZ electric control; Display objective magnification, fluorescence band and other states; Shortcut key setting;
Software	NOMIS advance 5.0 image analysis software
Host side port	1× relay lens Confocal left port; -1.8x M52 camera relay lens

DIMENSION FIGURE

Unit: mm

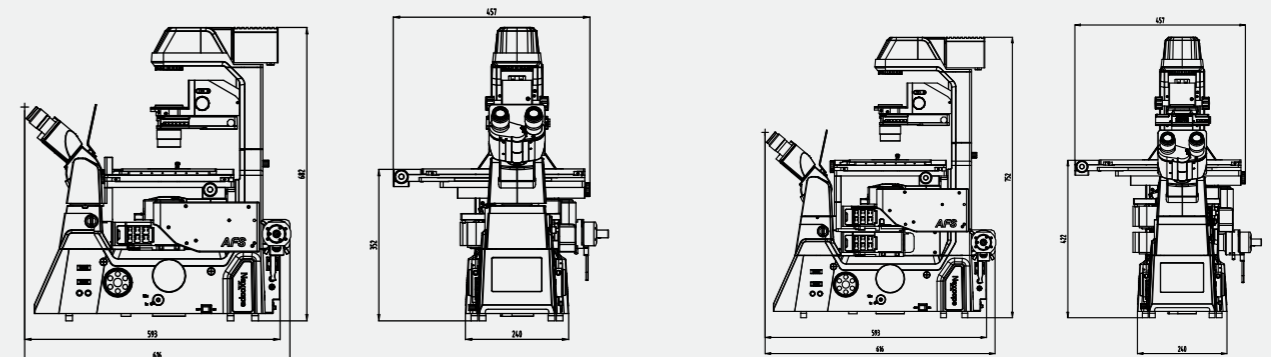

NIB1000-AT Single Layer Optical Path

NIB1000-AT Double Layer Optical Path